



# AIRWALL

Fixed Power Storage





# COMPRESSED AIR TECHNOLOGY

## Domestic clean energy storage set

Engineered with our compressed-air technology, the AirWall is a clean electricity generator. Coupled with a photovoltaic installation, it is able to store and supply a power up to 7kW at night. The modular design of the AirWall gives the facility to extend the capacity in power or duration by adding components. This is an innovative, flexible fixed power solution, ideal for your home or your business.

« Because sustainability must be accessible to all »

**Zero emission solutions:** As it uses only the solar energy and compressed air to run, this device does not depend on harmful batteries or fuels for operations.

**Reliable:** The life cycle of our safe tanks can guarantee more than 50 years. A filling test must be carried out every 5 years.



To triple the autonomy of its systems with the same amount of air, MDi patented a dual energy mode.

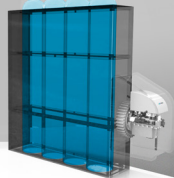
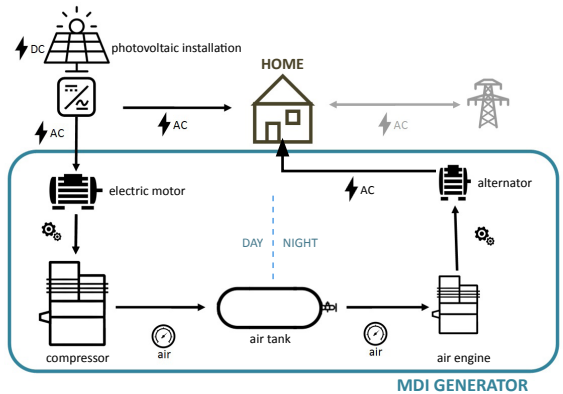

## Contact

17, rue des Bains  
L 1212 Luxembourg  
Tél. : 0035226262615  
info@mdi.lu



www.mdi.lu

